

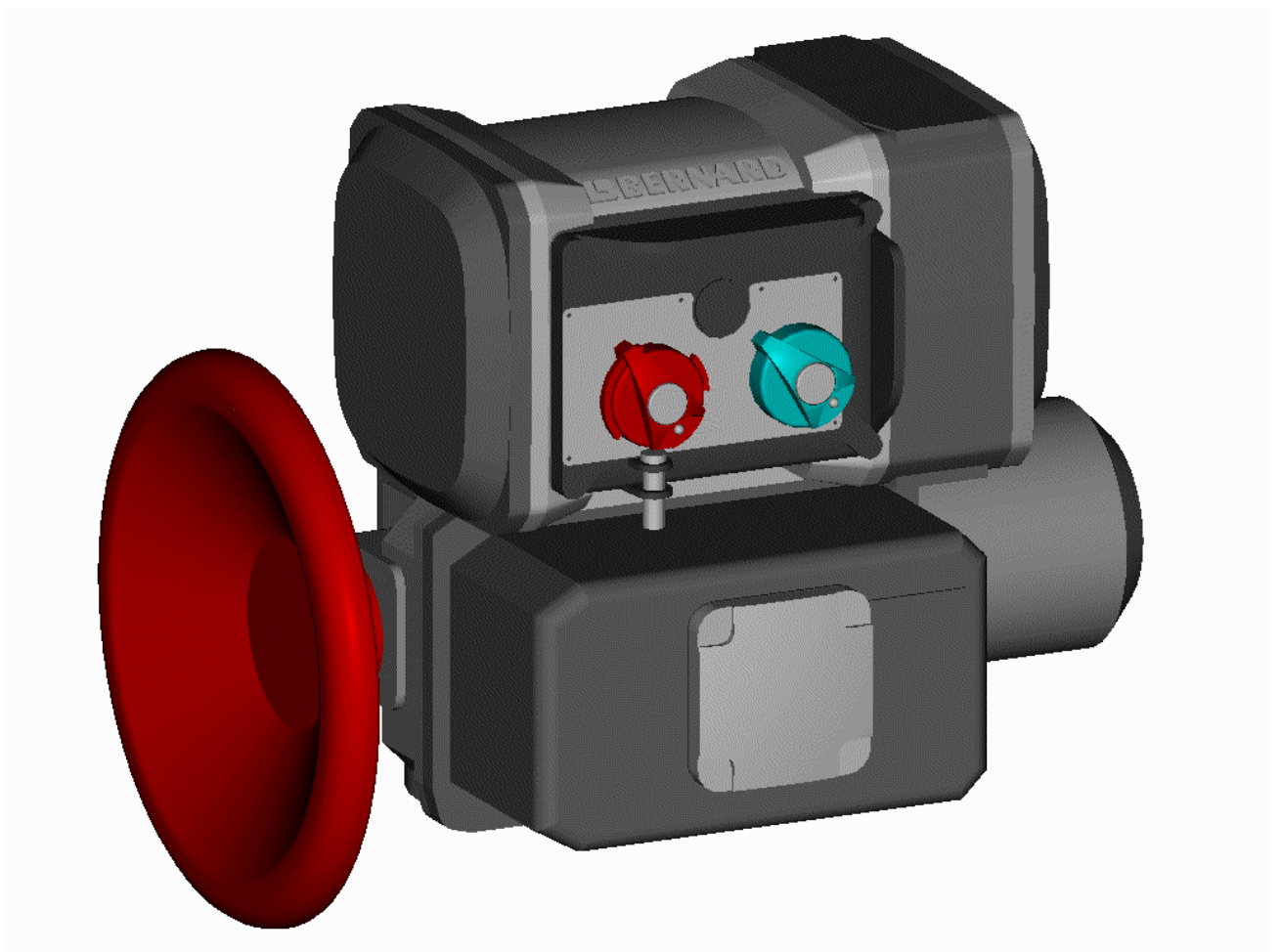

**"INTEGRAL +" CONTROLS
HANDBOOK
WITH POSITIONER POSIGAM+ OR MODUGAM+**



SUMMARY

1. INTRODUCTION.....	3
2. CONFIGURATION.....	4
3. POWER SUPPLY.....	5
3.1 ACTUATOR POWER SUPPLY	5
3.2 OUTPUT POWER SUPPLY.....	5
4. ACTUATOR OPERATION.....	6
4.1 DIRECTION OF ROTATION	6
4.2 CLOSING TYPE.....	6
4.3 BY-PASS OF OPEN TORQUE SWITCH WHEN STARTING TO OPEN FROM CLOSED POSITION.....	7
4.4 ROTATION REVERSE DELAY.....	7
5. REMOTE CONTROL.....	8
5.1 DRY CONTACTS CONTROL.....	8
5.2 VOLTAGE CONTROL.....	8
5.3 SINGLE DRY CONTACT CONTROL	9
5.4 PRIORITY TO OPEN OR TO CLOSE	10
5.5 EMERGENCY CONTROL (ESD).....	11
5.6 LOCAL CONTROL INHIBITION	12
6. LOCAL CONTROL	13
6.1 SELF-HOLDING LOCAL CONTROL	13
6.2 LOCAL STOP	14
6.3 GENERAL STOP.....	14
6.4 LOCAL / REMOTE SELECTOR PADLOCK	15
7. INDICATIONS.....	16
7.1 BLINKING INDICATIONS	17
7.2 INDICATION RELAY N°1	17
7.3 INDICATION RELAY N°2	18
7.4 INDICATION RELAY N°3	19
7.5 INDICATION RELAY N°4	20
7.6 FAULT MONITORING RELAY.....	21
8. FUSES PROTECTION.....	23
9. POSITIONER OPTION.....	24
9.1 INPUT SIGNAL CONFIGURATION	25
9.1.1 Operation with signal 0-20 mA	25
9.1.2 Operation with signal 0-10 V.....	25
9.2 OPERATION DIRECTION CONFIGURATION	25
9.3 ‘STAY PUT’ FUNCTION CONFIGURATION	26
9.4 DEAD BAND ADJUSTMENT.....	26
9.5 LOCAL OPERATION.....	26
9.6 ADJUSTMENT OF 0%	27
9.7 ADJUSTMENT OF 100%	27
9.8 SPLIT RANGE.....	27
9.9 OPERATION WITH A TRANSMITTER 4-20MA.....	28
9.10 REMOTE CONTROL AUTO / ON-OFF CONTROL.....	28
10. OPTION TIMING CONTROL BOARD.....	29
11. OPTION LOCAL INDICATION	29

1. INTRODUCTION

The configuration panel of the card INTEGRAL+ allows to adapt the actuator at each particular application. Information to be transmitted and actuator behaviour configuration are set with switches and jumpers on the panel. The actuator is deliverable with standard configuration, or optional configuration if requested at order.

The configuration can be change on site.

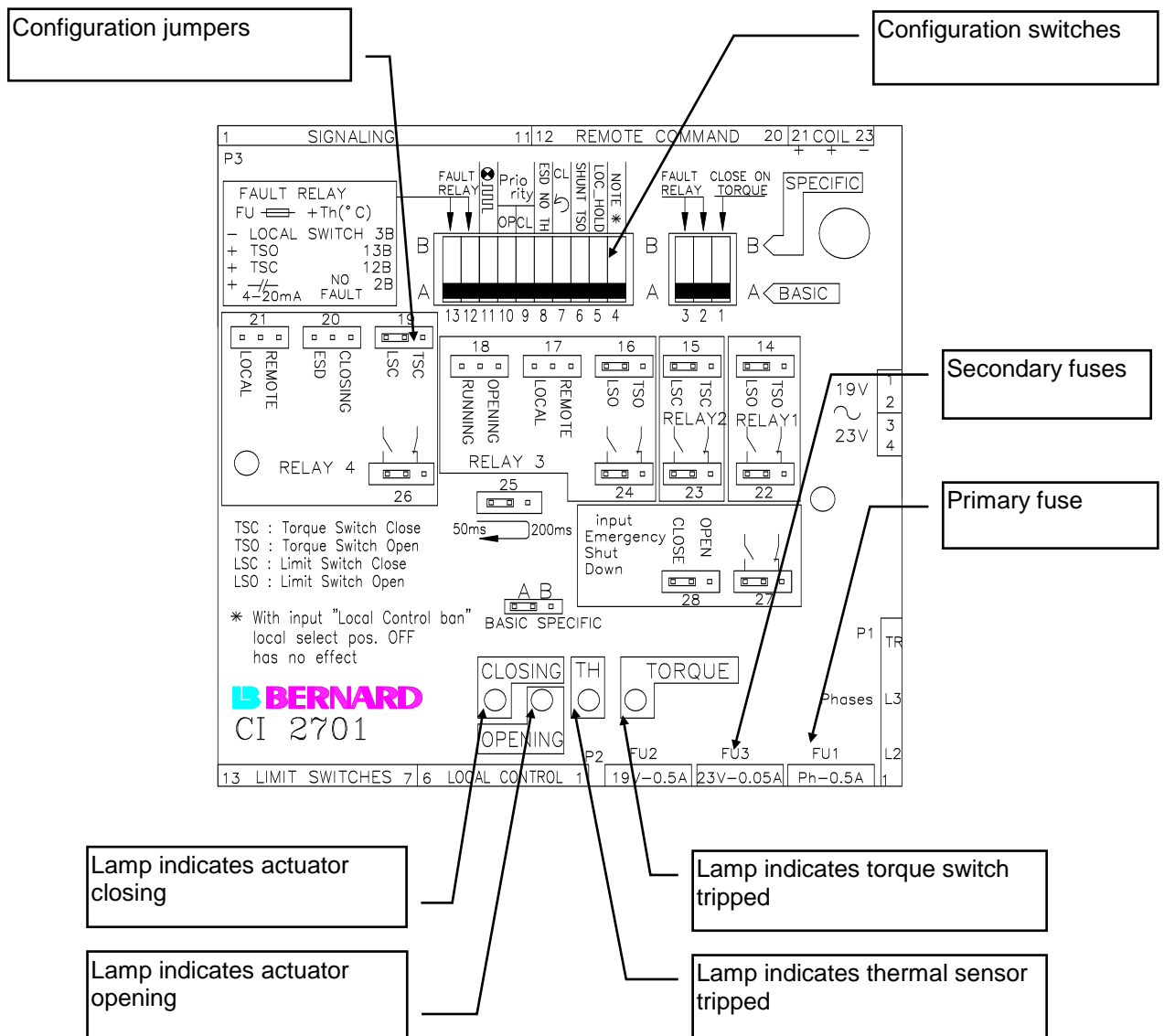

2. CONFIGURATION

Configuration is easily done by moving switches and jumpers.

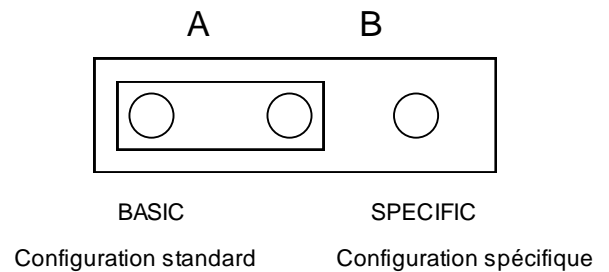
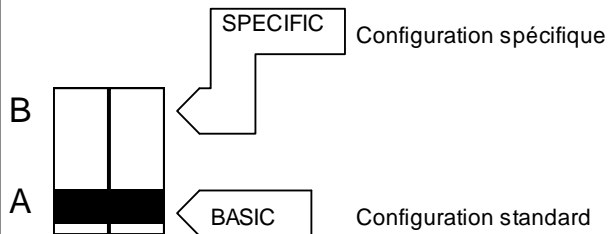
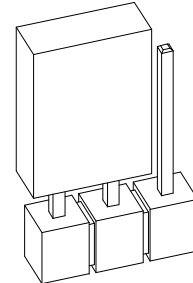
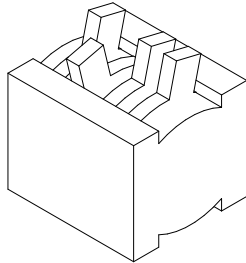

Switches configuration

Jumpers configuration

In “standard” configuration, the most common, all the switches and jumpers are in position A.

3. POWER SUPPLY

3.1 Actuator power supply

Actuator power supply can be 3 phase, single phase or DC.

The electronic board includes an automatic phase correction device and a detection of missing phase device.

In 3 phase supply, whatever the power connection, the actuator always rotates in the right direction.

If, in 3 phase supply, one phase is lost, the actuator stops automatically and the monitoring relay drops.

☛ **Jumper 100 support (located on lower board)**

In single phase or DC supply, one must inhibit the automatic phase correction and the detection of missing phase by moving the jumper 100 to position M.

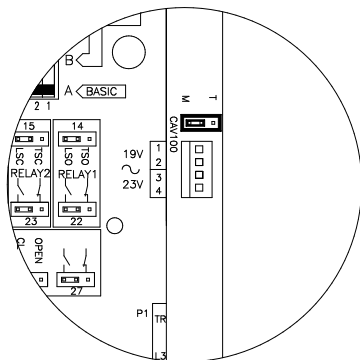

☛ Single phase power supply or DC supply

3.2 Output power supply.

One power supply unit 23V - 1,2VA DC is available (through the card CI2701) to power a remote position current transmitter and remote controls dry contacts. This power supply unit is isolated from the other electrical circuits.

4. ACTUATOR OPERATION

4.1 Direction of rotation

In standard, the actuator closes clockwise. According to the type of valve, one must sometimes close counter-clockwise.

☞ Switch 7

Move the switch 7 to position B for the valves closing counter-clockwise. This switch reverses :

- The motor direction of rotation
- The limit switches
- The torque switches

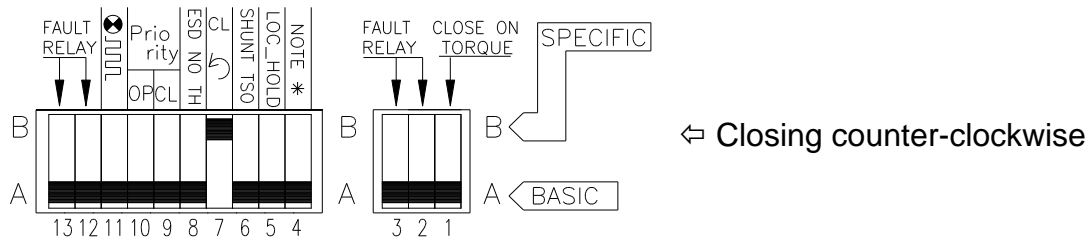

4.2 Closing type

In standard, the actuator closes on limit switch. According to the type of valve, one must sometimes close on a torque [instead of a position].

☞ Switch 1

Move switch 1 to position B for closing on torque switch. The associated limit switch must also be operated when the valve is closed.

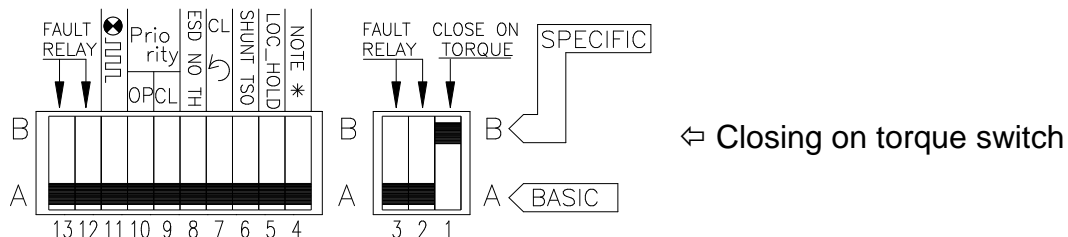

The limit switch is used for valve closed indication and also allows to detect stopping on torque switch at mid-stroke as a fault and stopping on torque switch in closed position as normal.

4.3 By-pass of open torque switch when starting to open from closed position

In standard, the open torque switch is active on the whole actuator stroke.

Switch 6

Move switch 6 to position B to by-pass the open torque switch by the closed limit switch when starting to open from the closed position.

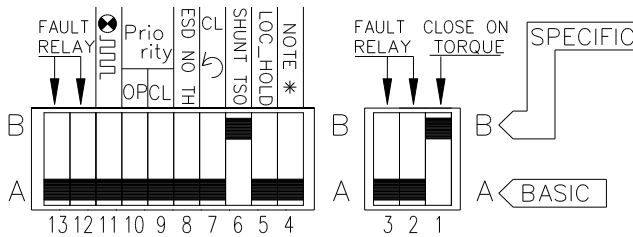

⇔ By-pass the open torque switch by the closed limit switch in closed position

This must be used when actuator including mechanically maintained torque switches [SR type] is set for closing on torque switch. This avoid the open torque switch to trip when starting to open.

4.4 Rotation reverse delay

In standard the reverse delay is 50ms. Jumper on support 25 in position 50ms.

Jumper support 25

Move the jumper on support 25 to position 200ms to have a reverse delay of 200ms.

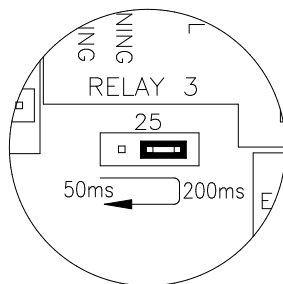

⇔ Reverse delay of 200 ms

Note : the setting of the reverse delay is a factory setting. It allows the use of bigger single phase motors.

5. REMOTE CONTROL

Remote control of an actuator equipped with the INTEGRAL+ can be done from an external voltage supply or an internal voltage supply..

Inputs on the board are completely isolated by opto-isolators.

Pulse commands (with self-holding) requires 4 wires connected to the customer terminal board: Common, stop, open and close. If the stop button is not used, do not connect the wire STOP, open contact (or close) must be maintained to operate the actuator.

5.1 Dry contacts control

In case of dry contact control, a jumper must be put on customer terminals 31-32.

Pulse remote command

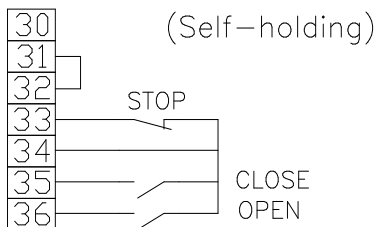

Remote command without self-holding

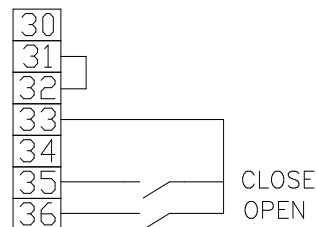

5.2 Voltage control

Remote control can be done either in AC or DC voltage.

For lower voltages from 10 to 55V, use common terminal 31.

For higher voltages from 55 to 250V, use common terminal 30

Caution : do never connect voltage higher than 55V on common terminal 31.

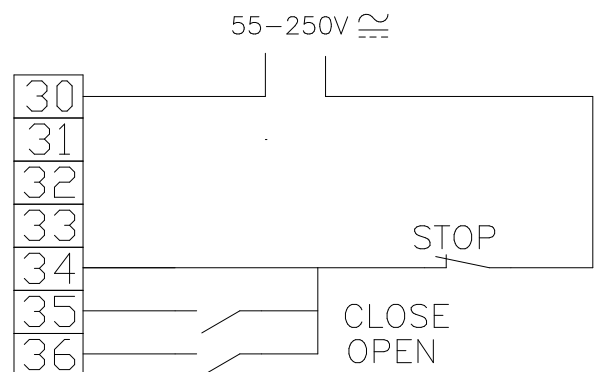
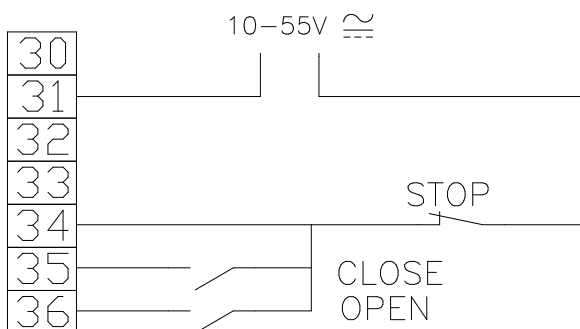

To cancel self holding do not connect terminal 34

5.3 Single dry contact control

It is possible to control the actuator with a single external dry contact.

- Contact closed : opening of the valve
- Contact open : closing of the valve

One must configure the actuator for priority to open (see 5.4)

The opposite control is possible :

- Contact closed : closing of the valve
- Contact open : opening of the valve

One must configure the actuator for priority to close (see 5.4)

Opening by single
contact closing

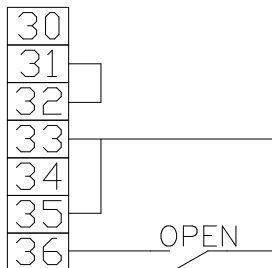

Configuration :
Priority to open
(switch 10 to position B)

Closing by single
contact closing

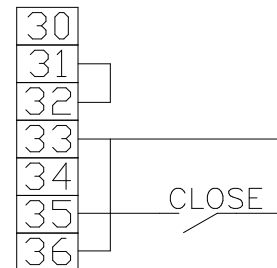

Configuration :
Priority to close
(switch 9 to position B)

5.4 Priority to Open or to Close

In standard there is no priority to open or to close. These priorities are used to :

- Change the direction during operation without going through a stop command. In that case priority to Open and to Close are needed.
- Give priority to one position : if the actuator receives both open and close command and a priority to open is set, then the actuator will start opening.
- Control by a single dry contact

☞ **Switch 9**

☞ **Switch 10**

Move switch 9 to position B for priority to Close.

Move switch 10 to position B for priority to Open

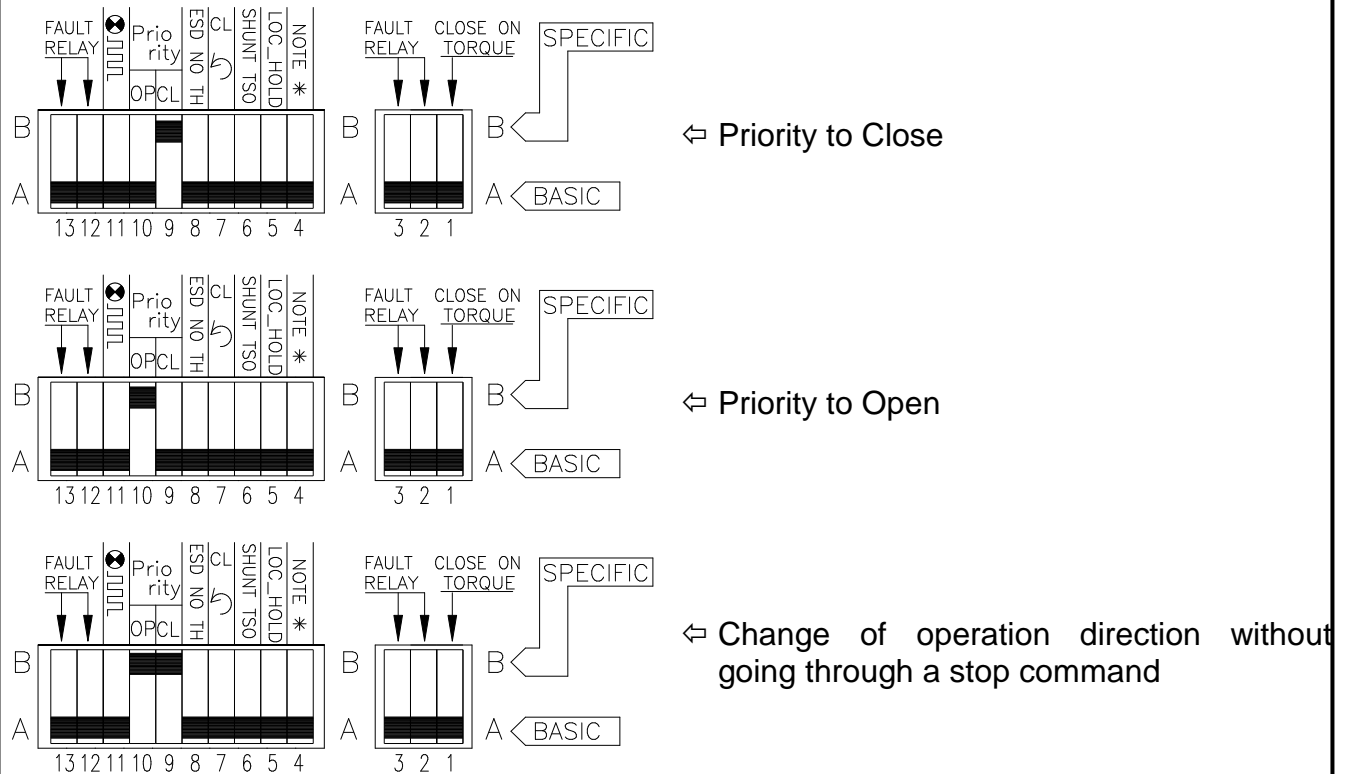

Priority command stops the pending operation and is immediately active.

5.5 Emergency control (ESD)

ESD (Emergency Shut Down) is a remote emergency control, with priority on all other controls. According to the valve operation, ESD can be open command or close command. To increase the availability of the actuator in extreme conditions, ESD can also override the motor thermal sensor.

Note : ESD is not available when local / remote selector is in position "OFF".

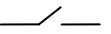
In standard, ESD control is performed by closing a contact. Jumper on support 27 position .

Jumper support 27

Move jumper on support 27 position  to have ESD by opening a contact.

Caution : In this configuration, if ESD input is not connected, the actuator receives a operation command when powered on. It is therefore recommended to add a jumper on the terminal board [in place of ESD] prior to power on.

In standard, ESD control is a close command. Jumper on support 28 position CLOSE.

Jumper support 28

Move jumper on support 28 to position OPEN for open command.

In standard, ESD control does not override the motor thermal sensor

Switch 8

Move switch 8 to position B to by-pass the motor thermal sensor when ESD control.

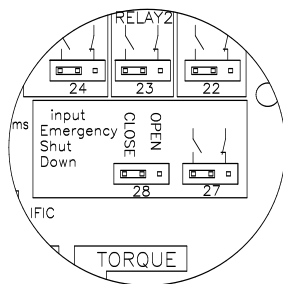

⇔ Configuration of ESD control:
Jumper support N°27 and N°28

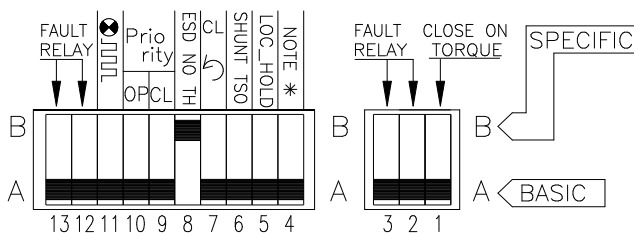

⇔ By-pass of motor thermal sensor when ESD control.

5.6 Local control inhibition

The inhibition of the local control is a remote command. This command freezes open and close commands sent in local and authorize remote commands even if the local / remote selector is in local position.

In standard configuration, local stop and general stop remain possible locally on the actuator.

For inhibition of local stop and general stop, see 6.3 (switch 4 on position B)

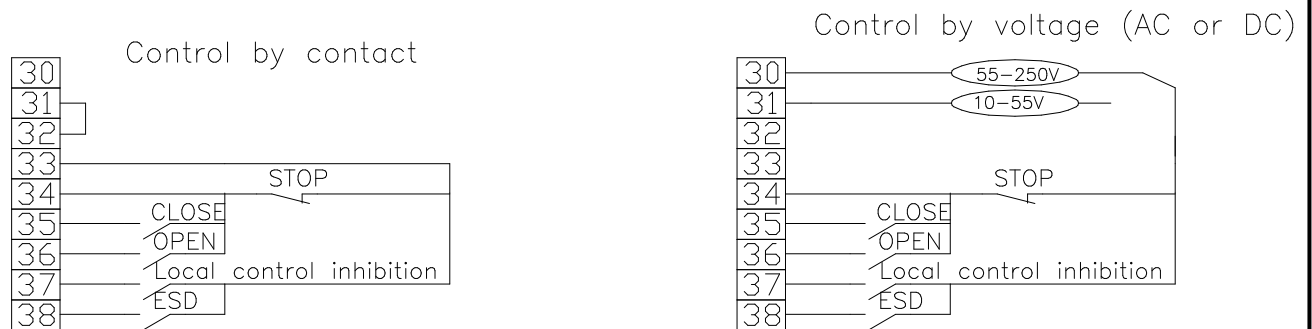

Note : the command inhibition of local control is not available with the option positioner. It is replaced [automatically] by the function "AUTO / ON-OFF CONTROL".

6. LOCAL CONTROL

As for remote control, local control can be used. A local selector allows to choose between remote and local control. The button for local control open, close allows to operate the actuator in the appropriate direction. Local stop is done by a momentary rotation of the local / remote selector.

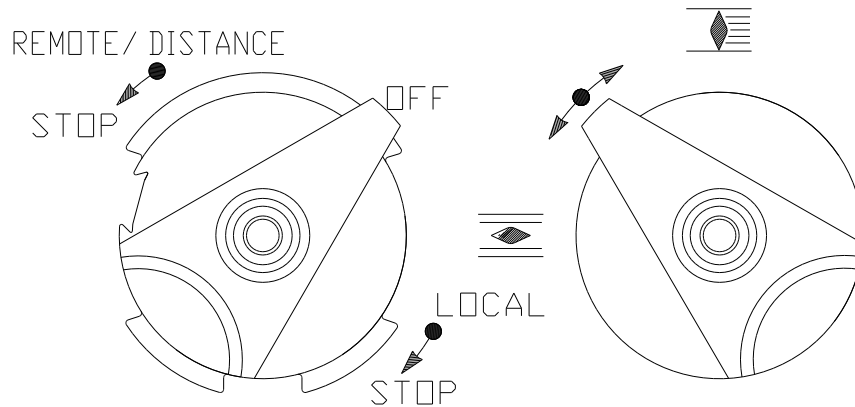

6.1 Self-holding local control

In standard, local controls are self-holding. (One pulse is enough to send a close or open command)

☞ Switch 5

Move switch 5 to position B to cancel the self-holding. (Open or close command must be maintained during the operation)

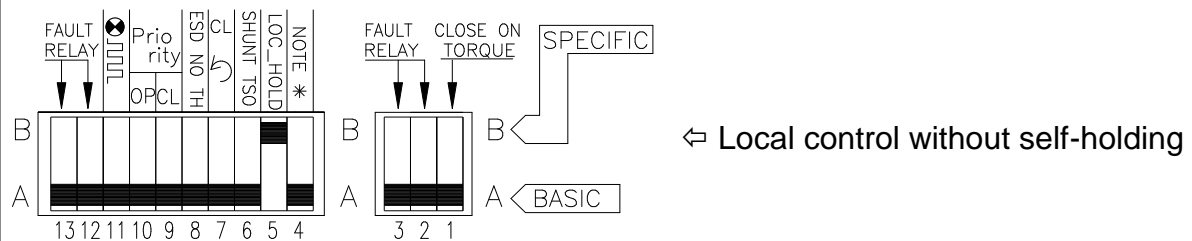

6.2 Local stop

In standard, it is possible to stop the actuator locally, even if the selector local / remote is on remote position.

☞ Locking pin

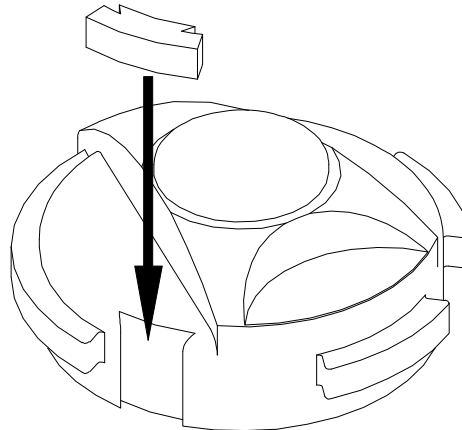

To inhibit a local stop when the selector is on remote position, fit the locking pin on the local / remote selector.

Nota : This inhibition is effective only when the selector is padlocked in the remote position.

6.3 General stop

In standard, it is possible to do a general stop of the actuator. Move the selector local / remote to position OFF. No electrical controls in local or remote is therefore possible.

If the remote command “ local control inhibition ” is used, priority remains to the function general stop.

☞ Switch 4

Move switch 4 to position B to prohibit local stop and OFF position when local control inhibition.

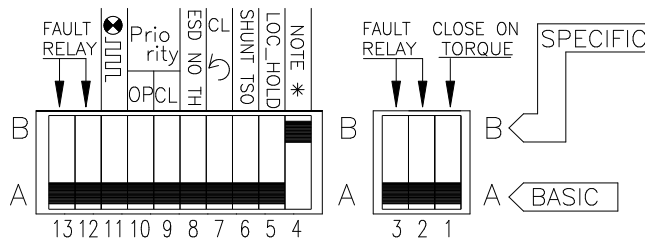

☞ Local stop impossible if local control inhibition.

6.4 Local / remote selector padlock

The local / remote selector can be padlocked in position OFF, local or remote.

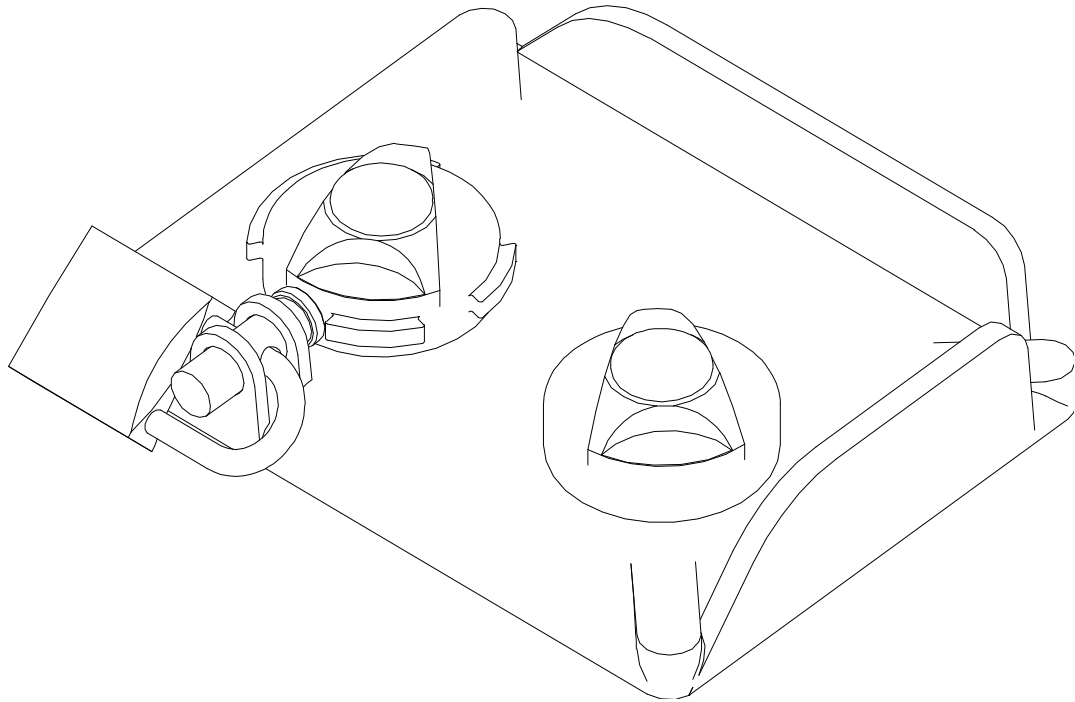

“ INTEGRAL + ” Controls**7. INDICATIONS**

Remote indication is done through 5 relays :

- Four relays ‘single contact’ for operation indications. Contacts can be normally open or normally closed.

Nota : Voltage free, relays are always with normally open contact.

- one reversing relay for fault monitoring.

Nota : The monitoring relay is normally energised and drops in case of fault.

Relays informations :

(Grey : standard configuration)

Relay N°	Information to be transmitted	Location of jumper	Customer terminals
Relay 1	Limit switch open Torque switch open	14 - LSO 14 - TSO	50 - 51
Relay 2	Limit switch close Torque switch close	15 - LSC 15 - TSC	52 - 53
Relay 3	Limit switch open Torque switch open Local/remote selector on local Local/remote selector on remote Actuator moving electrically Actuator opening electrically	16 - LSO 16 - TSO 17 - LOCAL 17 - REMOTE 18 - RUNNING 18 - OPENING	54 - 55
Relay 4	Limit switch close Torque switch close Actuator is receiving an emergency command (ESD) Actuator closing electrically Local/remote selector on local Local/remote selector on remote	19 - LSC 19 - TSC 20 - ESD 20 - CLOSING 21 - LOCAL 21 - REMOTE	56 - 57

7.1 Blinking indications

In standard, informations :

- Actuator running electrically
- Actuator opening electrically
- Actuator closing electrically

Are not blinking.

☞ **Switch 11**

Move switch 11 to position B to have the 3 informations blinking

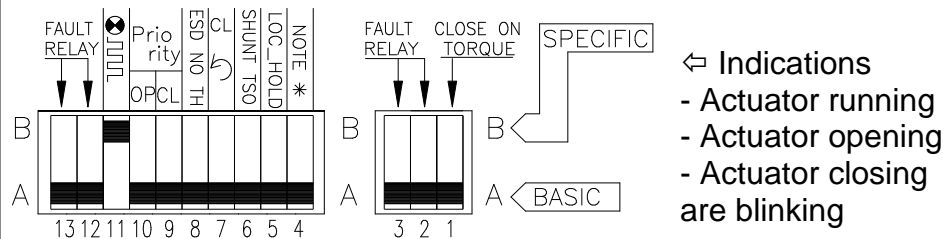

- ⇔ Indications
- Actuator running
 - Actuator opening
 - Actuator closing
- are blinking

7.2 Indication relay N°1

In standard, relay N°1 indicates limit switch open. Jumper on support 14 in position LSO (Limit Switch Open).

☞ **Jumper support 14**

Move jumper on support 14 to position TSO (Torque Switch Open) for relay N°1 to indicate torque switch open.

In standard, relay N°1 is with contact normally open. Jumper on support 22 in position

☞ **Jumper support 22**

Move jumper on support 22 position for relay N°1 to be with contact normally close.

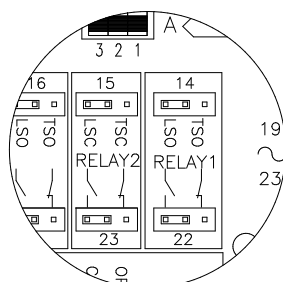

⇔ Configuration relay 1 : jumper support N°14 and N°22

7.3 Indication relay N°2

In standard, relay N°2 indicates limit switch close. Jumper on support 15 in position LSC (Limit Switch Close).

☞ **Jumper support 15**

Move jumper on support 15 to position TSC (Torque Switch Close) for relay N°2 to indicate torque switch close.

In standard, relay N°2 is with contact normally open. Jumper on support 23 in position 

☞ **Jumper support 23**

Move jumper on support 23 to position  for relay N°2 to be with contact normally closed.

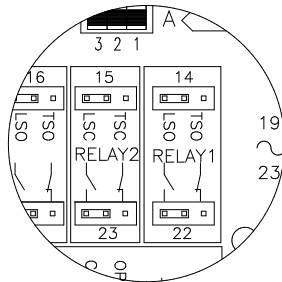

☞ Configuration relay 2 : Jumper support N°15 and N°23

7.4 Indication relay N°3

In standard, relay N°3 indicates limit switch open. Jumper on support 16 in position LSO (Limit Switch Open).

☞ **Jumper support 16**

☞ **Jumper support 17**

☞ **Jumper support 18**

- Move jumper on support 16 to position TSO (Torque Switch Open) for relay N°3 to indicate torque switch open.
- Move jumper on support 17 to position REMOTE for relay N°3 to indicate local/remote selector in position remote.
- Move jumper on support 17 to position LOCAL for relay N°3 to indicate local/remote selector in position local.
- Move jumper on support 18 to position OPENING for relay N°3 to indicate that actuator is running in opening direction.
- Move jumper on support 18 to position RUNNING for relay N°3 to indicate that actuator is running.

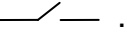
In standard, relay N°3 is with contact normally open. Jumper on support 24 in position .

☞ **Jumper support 24**

Move jumper on support 24 to position  for relay N°3 to be with contact normally closed.

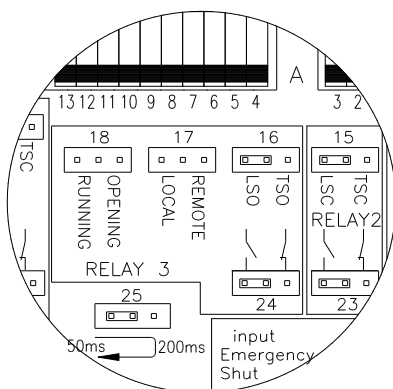

- ☞ Configuration relay 3 : jumper support N°16, 17, 18 and N°24
- ☞ 1 unique jumper for supports 16,17 and 18

7.5 Indication relay N°4

In standard, relay N°4 indicates limit switch closed. Jumper on support 19 in position LSC (Limit Switch Close).

🔗 **Jumper support 19**

🔗 **Jumper support 20**

🔗 **Jumper support 21**

- Move jumper on support 19 to position TSC (Torque Switch Close) for relay N°4 to indicate torque switch close.
- Move jumper on support 20 to position CLOSING for relay N°4 to indicate that actuator is running in closed direction.
- Move jumper on support 20 to position ESD (Emergency Shut Down) for relay N°4 to indicate that actuator is receiving an ESD command.
- Move jumper on support 21 to position REMOTE for relay N°4 to indicate local/remote selector in position remote.
- Move jumper on support 21 to position LOCAL for relay N°4 to indicate local/remote selector in position local.

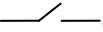
In standard, relay N°4 is with contact normally open. Jumper on support 26 in position .

🔗 **Jumper support 26**

Move jumper on support 26 to position  for relay N°4 to be with contact normally closed.

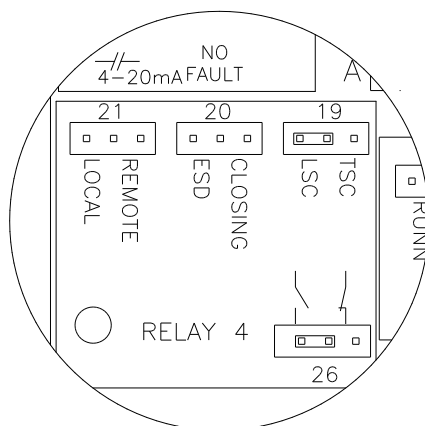

- ⇨ Configuration relay 4 : jumper support N°19, 20, 21 and N°26
- ⇨ 1 unique jumper for supports 19, 20 and 21

7.6 Fault monitoring relay

The fault monitoring relay indicates a non-availability of the actuator or an abnormal operation. The fault monitoring relay is normally energized, and is disenergized in case of fault.

The relay is disenergized upon the following events:

- Loss of main power supply, control voltage, fuse.
- Loss of 1 phase (in case of 3 phase supply)
- Tripping of motor thermal protection
- Loss of input signal 4-20mA (with option positioner)*
- Local/remote selector in position local or off**

** On version without positioner, switch N°2 has no effect.*

*** In case of local controls inhibition, selector in position local is not indicated as a fault, because actuator is still available for the remote commands.*

The user can modify the conditions upon which the relay is disenergized.

☞ Switch 2

Move switch 2 to position B for loss of input signal 4-20mA not indicated as a fault. (Option positioner only).

☞ Switch 3

Move switch 3 to position B for local/remote selector in local or off not indicated as a fault.

☞ Switch 12

Move switch 12 to position B for tripping of torque switch close to be a fault.

☞ Switch 13

Move switch 13 to position B for tripping of torque switch open to be a fault.

“ INTEGRAL + ” Controls

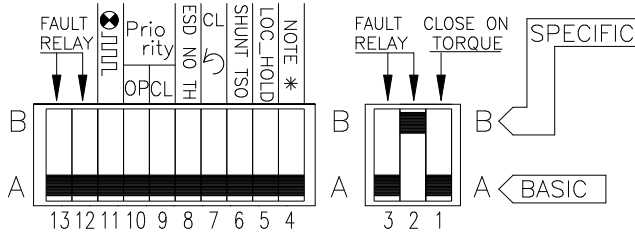

⇔ Loss of input signal 4-20mA is not a fault. (Option positioner only).

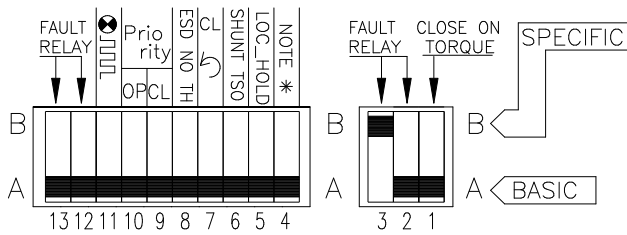

⇔ Local/remote selector in local or off is not a fault.

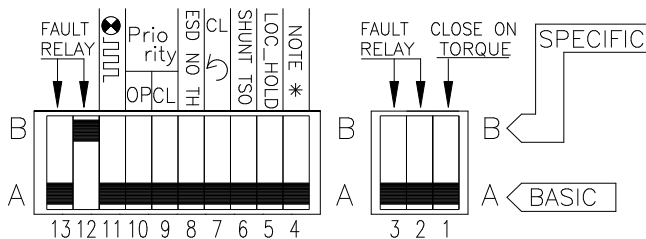

⇔ Tripping of torque switch close is a fault.

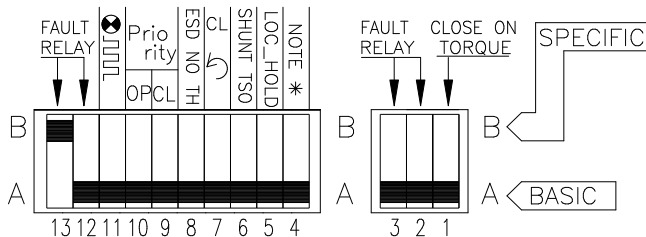

⇔ Tripping of torque switch open is a fault.

Note : Supervisor system is able to detect if the valve close on torque, and in this case there is no fault indication

8. FUSES PROTECTION

Accessibility :

- Switch off power supply on actuator.
- Remove cover on terminal box.
- Unfasten the 4 screws located near the cover's screws.
- Move a few centimeters backward the electric block, until seeing on the side the fuses supports.
- Unfasten the covers and change the fuses if necessary.

Fuses data :

FU1 : transformer primary fuse	6,3 x 32mm - 0,5A - 500V
FU2 : transformer secondary fuse	5 x 20mm - 0,5A
FU3 : transformer secondary fuse	5 x 20mm - 0,05A

9. POSITIONER OPTION

The option positioner is connected to the basic board CI2701. The positioner allows the actuator to reach a position proportionally to a command input signal. The configuration panel of L. BERNARD positioner allows:

- To give local positioning commands
- To adapt the actuator to the type of input signal
- To configure the reaction of the actuator in case of loss of input signal

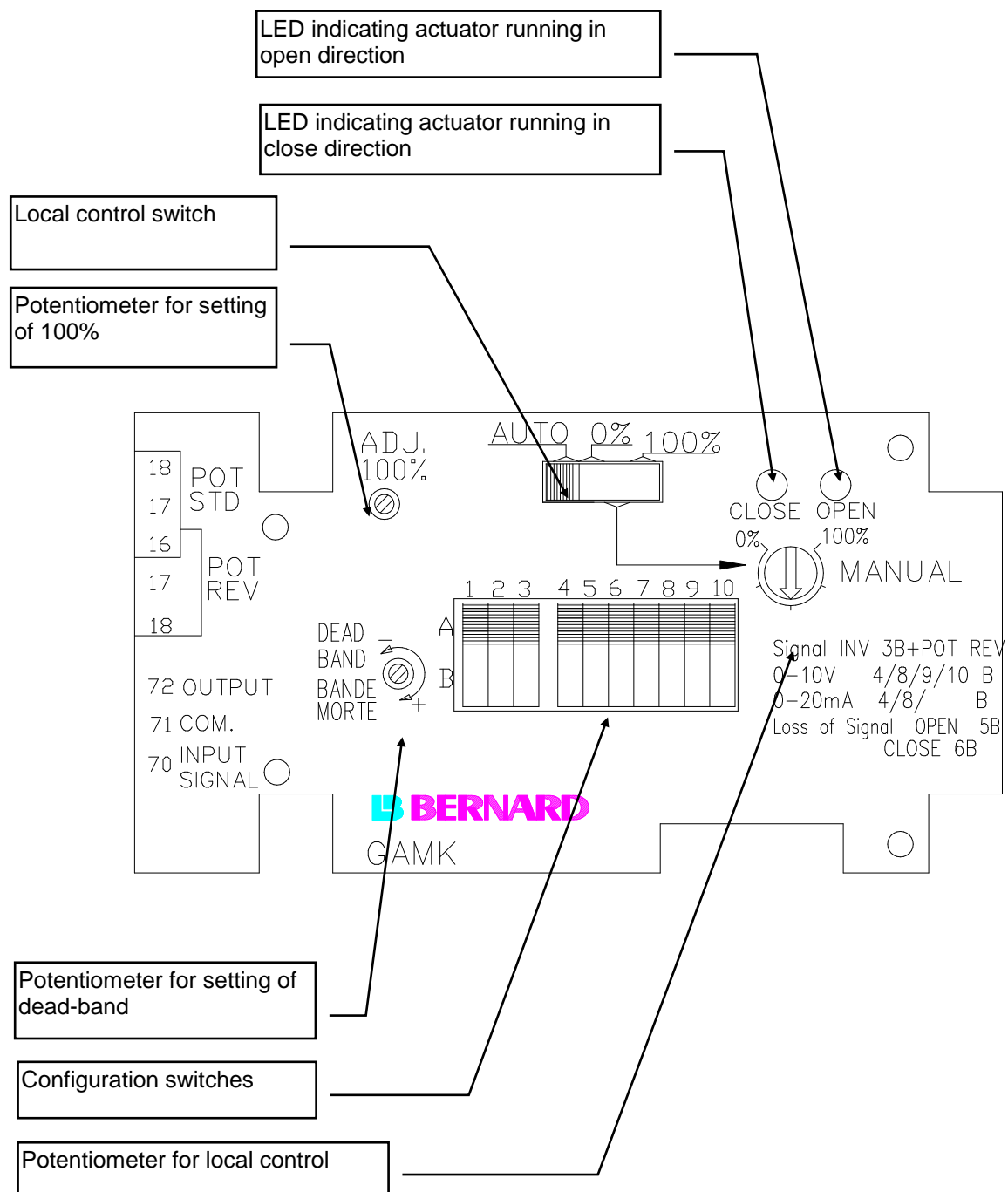

“ INTEGRAL + ” Controls

9.1 Input signal configuration

The standard input signal is 4-20 mA

9.1.1 Operation with signal 0-20 mA

☞ **Switch 4**

☞ **Switch 8**

Move switches 4 and 8 to position B for operation with signal 0-20mA. The output signal [position indication] is also 0-20 mA.

9.1.2 Operation with signal 0-10 V

☞ **Switch 4**

☞ **Switch 8**

☞ **Switch 9**

☞ **Switch 10**

Move switches 4, 8, 9 and 10 to position B for operation with signal 0-10 V. The output signal is 0-20 mA.

9.2 Operation direction configuration

The standard is 4 mA valve closed and 20 mA valve open.

☞ **Switch 3**

☞ **Potentiometer connection**

Move switch 3 to position B, and move actuator potentiometer connection from position "POT STD" to position "POT REV" to obtain 4 mA valve open, and 20 mA valve closed.

Operation direction configuration				
Type of input signal	Open		Close	
		4mA -----> 20mA	0mA -----> 20mA	4mA -----> 20mA
		0v -----> 10V		0v -----> 10V
Valve action	Closing clockwise	Closing counter-clockwise	Closing clockwise	Closing counter-clockwise
Configuration	Standard	Integral+(CI2701) : switch 7 on B Reverse potentiometer	Positioner (GAMK) : switch 3 on B Reverse potentiometer	Integral+(CI2701) : switch 7 on B Positioner (GAMK) switch 3 on B

9.3 'Stay put' function configuration

With input signal 4-20 mA, it is possible to configure a failsafe position in case of loss of input signal.

In standard, the function is active, and the actuator stays in position in case of loss of input signal.

☞ **Switch 5**

☞ **Switch 6**

☞ **Switch 8**

Move switch 5 to position B for actuator to open in case of loss of input signal

Move switch 6 to position B for actuator to close in case of loss of input signal

Move switch 8 to position B to dis-activate the 'stay put' function.

Caution : in case of input signal 0-20 mA or 0-10 V, the 'stay put' function cannot be used and must be dis-activated. Move switch 8 to position B.

9.4 Dead band adjustment

This adjustment is factory done, but one can adjust it with the potentiometer "DEAD BAND". To reduce the dead band turn it counter-clockwise.

Caution : Reducing the dead band too much will provoke "hunting" on the actuator.

9.5 Local operation

One can simulate an input signal 4-20 mA locally to check the operation of the actuator. The local/off/remote selector must be on the remote position

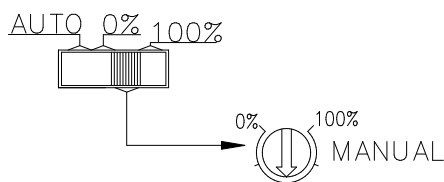

- ⇔ AUT : Operation by external signal
- ⇔ 0% : Internal signal 0% (4mA in standard)
- ⇔ MAN : Internal signal adjustable from 0 to 100%
- ⇔ 100 % : Internal signal 100% (20mA in standard)

Move local control switch to position 0%,MAN or 100%. Turn potentiometer "MAN" to simulate an input signal 4-20 mA.

9.6 Adjustment of 0%

The local/off/remote selector must be on remote position. Move local control switch to position 0% for the actuator to receive a closing command (4mA).

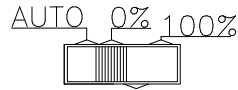

Case N°1 : actuator starts closing and stops before the close limit switch.

Turn actuator potentiometer progressively to bring the actuator on the close limit switch, LED on. Turn potentiometer slowly in opposite direction until the red LED goes off.

Case N°2 : actuator starts closing, stops on the close limit switch, and the LED indicating closing is still on.

Turn actuator potentiometer progressively to off the LED.

9.7 Adjustment of 100%

The local/off/remote selector must be on remote position. Move local control switch to position 100% for the actuator to receive an opening command (20mA).

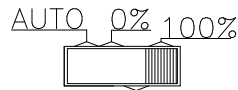

Case N°1 : actuator starts opening and stops before the open limit switch.

Turn potentiometer "ADJ 100%" (adjustment of 100%) progressively clockwise to bring the actuator on the open limit switch. Turn slowly this potentiometer in opposite direction until the green LED goes off.

Case N°2 : actuator starts opening, stops on the open limit switch, and the green LED is still on.

Turn potentiometer "ADJ 100%" (adjustment of 100%) progressively counter-clockwise to off the green LED.

9.8 Split Range

The positioner card can be configured for split range.

Split range means input signals 4-12mA and 12-20mA. The end user signal is normal :4-20mA. A first actuator is set to receive a signal from 4 to 12mA and a second actuator is set to receive a signal from 12 to 20mA. Each actuator receives the signal 4-20mA. The first one opens completely from 0 to 50% of the signal and the second from 50 to 100% of the signal.

“ INTEGRAL + ” Controls**☞ Switch 1****☞ Switch 2**

Move switch 1 to position B for the actuator to receive an input signal 12-20mA.

Move switch 2 to position B for the actuator to receive an input signal 4-12mA.

9.9 Operation with a transmitter 4-20mA

In standard the actuator potentiometer is used to know the valve position.

☞ Switch 7

Move switch 7 to position B for operation with a transmitter 4-20mA instead of the actuator potentiometer. The CI2701 board can provide the power supply to the transmitter TAM or FSG.

9.10 Remote control AUTO / ON-OFF CONTROL

With a positioner, one can do remote control by a signal 4-20mA or by open/close/stop commands. The input AUTO / ON-OFF CONTROL on the customer terminal board allows to switch from one type of control to the other one.

See chapter 5 "remote control" for the configuration of the open and close commands.

Note : The remote controls " AUTO / ON-OFF CONTROL " and "LOCAL CONTROL INHIBITION" use the same input on the customer terminal board. The implementation of the positioner automatically allocates this input to the function AUTO / ON-OFF CONTROL. The function "LOCAL CONTROL INHIBITION" cannot be used with a positioner.

10. OPTION TIMING CONTROL BOARD

The timing control board allows to reduce the operating speed of the actuator, to protect for example a pipeline from the effects of hammering.

This additional board is connected with the main board.

Two potentiometers allow to set the running time and the stop time for an intermittent operation.. (The settings in open and close direction are independants).

One can use an additional limit switch to start the intermittent operation from a preset position.

11. OPTION LOCAL INDICATION

In option a local indication through a window at the local controls level shows the actuator status.

- Lamp valve open
- Lamp valve closed
- Lamp actuator power-on

“ INTEGRAL + ” Controls

12. FUNCTIONAL FAULTS OF INTEGRAL+ VERSION

In case of doubt as to the unit's functionality, firstly set the local/remote selector switch to "local" and actuate the local open/close controls.

PROBLEM	CAUSE	CORRECTIVE ACTION
<p>No operation</p>	<p>Actuator power supply</p> <p>A local control inhibit command is present.</p> <p>An emergency control command is present and inhibits all other commands.</p> <p>Fuse blown</p> <p>Power supply type configuration</p> <p>Tripping of motor thermal protective device</p> <p>The declutchable manual control handwheel remained engaged (only on versions with electrical safety contact)</p> <p>Configuration jumpers are incorrectly set or missing</p>	<p>Check the power supply voltage (terminals L1, L2, L3 in 3 PH voltage). The voltage is specified on the identification plate.</p> <p>Check that the Actuator receives no local control inhibit command.</p> <p>With the unit "off", the local control inhibit wire, connected to terminal 37 may be removed to carry out a functional check of the Actuator.</p> <p>Check that the Actuator receives no emergency command.</p> <p>With the unit "off", jumper #27 may be removed from the "integral+" board, taking care to record its position to make sure it is replaced at the correct location. With the jumper removed, the ESD function is inhibited, and a functional check of the Actuator can be carried out. Return the jumper to original location.</p> <p>Check fuses and replace as required.</p> <p>Check position of jumper 100 on the "Integral+" board.</p> <p>Three-phase : position T Single-phase or DC: position M</p> <p>The TH light on the "Integral+" board configuration panel indicates thermal tripping of thermal protective device. The Actuator will again be available after the motor has cooled off.</p> <p>Check that the handwheel is in disengaged position.</p> <p>There must be 11 jumpers on the "Integral+" board.</p> <p>There shall be only one jumper on jumper 16-17-18 support and only one jumper on jumper 19-20-21 support.</p>

“ INTEGRAL + ” Controls

PROBLEM	CAUSE	CORRECTIVE ACTION
The actuator operates in local mode, not in remote mode	Local/remote selector switch set to local or to off. Contact control: no voltage across terminals 32 and 33. Voltage control: inappropriate input voltage.	Set the local/remote selector switch to remote. Check that a shunt is present at the client terminal strip between terminals 31 and 32. Check fuse FU3 on the "Integral+" board. Check connection in voltage control mode: Voltage 10 to 55 V: Terminal strip 31 Voltage 55 to 250 V: Terminal strip 30
The actuator operates in remote mode, not in local mode	Local/remote selector switch set to remote or to off A local control inhibit command is present.	Set the local/remote selector switch to local. Check that the Actuator receives no local control inhibit command. With the unit "off", the local control inhibit wire, connected to terminal 37 may be removed to carry out a functional check of the Actuator.
The actuator does not rotate in the correct rotational direction	Configuration incorrect The motor has been unwired and rotates in the reverse direction (motor replacement)	Check the rotational direction configuration. Switch #7 of the "Integral+" board: Position A: clockwise closing Position B: counterclockwise closing When replacing a motor, wire markings must be observed. In case of doubt, check rotational direction. To reverse the motor rotational direction, change over wires 2 and 3 of the motor terminal strip.
The Actuator does not stop on the closing limit switch.	The Actuator is configured for torque closing. The closing limit switch is misadjusted. The motor has been unwired and rotates in the reverse direction (motor replacement).	Check closing configuration (switch 1 of the "Integral+" board). Adjust the closing limit switch. The closing limit switch must be actuated with the valve closed (even if the Actuator is set for torque closing). When replacing a motor, wire markings must be observed. In case of doubt, check rotational direction. To reverse the motor rotational direction, change over wires 2 and 3 of the motor terminal strip.
The Actuator does not stop on the	The opening limit switch is misadjusted.	Adjust the opening limit switch. The opening limit switch must be actuated with

“ INTEGRAL + ” Controls

PROBLEM	CAUSE	CORRECTIVE ACTION
opening limit switch		the valve open.
	The motor has been unwired and rotates in the reverse direction (motor replacement).	When replacing a motor, wire markings must be observed. In case of doubt, check rotational direction. To reverse the motor rotational direction, change over wires 2 and 3 of the motor terminal strip.
Indications are inoperative	The Actuator is "off"	Indications are only available with the Actuator "on".
The torque limiter indications are inoperative	Configuration incorrect The torque limiter has been actuated manually.	Check that the concerned indication relay has been configured for torque limiter indication. The jumper of the "Integral+" board is set to : TS0 for opening torque limiter TSC for closing torque limiter The electronics only store the limiter data if a manoeuvre is in progress. The electronics further only stores the data for the torque limiter corresponding to the rotational direction.
The torque limiter indication does not return to initial condition once the torque limiter is no longer actuated.	Torque limiter data storage	The torque limiter data are stored electronically. To clear a torque limiter memory, a reverse order must be sent.

13 FUNCTIONAL FAULTS OF POSITIONER VERSIONS

In case of doubt as to the unit's functionality, firstly set the local/remote selector switch to "local" and actuate the local open/close controls.

PROBLEM	CAUSE	CORRECTIVE ACTION
No operation	Actuator power supply An emergency control command is present and inhibits all other commands.	Check the power supply voltage (terminals L1, L2, L3 in three-phase voltage). The voltage is specified on the identification plate. Check that the Actuator receives no emergency control command. With the unit "off", jumper #27 may be removed from the "integral+" board, taking care to record its position to make sure it is replaced at the correct location. With the jumper removed, the ESD function is inhibited, and a functional check of the

“ INTEGRAL + ” Controls

PROBLEM	CAUSE	CORRECTIVE ACTION
	<p>Fuse blown</p> <p>Power supply type configuration</p> <p>Tripping of motor thermal protective device</p> <p>The declutchable manual control handwheel remained engaged (only on versions with electrical safety contact)</p> <p>Configuration jumpers are incorrectly set or missing</p>	<p>Actuator can be carried out. Return the jumper to original location.</p> <p>Check fuses of "Integral+" board and replace as required.</p> <p>Check position of jumper 100 on the "Integral+" board. Three-phase : position T Single-phase or DC: position M</p> <p>The TH light on the "Integral+" board configuration panel indicates thermal tripping of thermal protective device. The Actuator will again be available after the motor has cooled off.</p> <p>Check that the handwheel is in disengaged position.</p> <p>There must be 11 jumpers on the "Integral+" board. There shall be only one jumper on jumper 16-17-18 support and only one jumper on jumper 19-20-21 support.</p>
<p>The actuator operates in local open/close control mode, not in positioner mode</p>	<p>Local/remote selector switch set to local or to off.</p> <p>An auto/on-off control order is present and inhibits the positioner.</p> <p>The connector connecting the positioner board to the "Integral+" board is disconnected.</p> <p>The actuator repeater potentiometer is incorrectly set.</p> <p>Input signal incorrect</p>	<p>Set the local/remote selector switch to remote to use the positioner (even when the positioner is set to manual).</p> <p>Check that the Actuator receives no Auto/on-off control command.</p> <p>Disconnect this remote control (terminal 37) as required for confirmation.</p> <p>Check the positioner board-Integral board connection.</p> <p>Turn the Actuator potentiometer by a quarter-turn and repeat adjustments in accordance with commissioning instructions.</p> <p>Check input signal configuration on the positioner board :</p> <p>4-20 mA signal : Switch 4 set to A Switch 9 set to A</p>

“ INTEGRAL + ” Controls

<p>PROBLEM</p>	<p>CAUSE</p>	<p>Switch 10 set to A</p> <p>CORRECTIVE ACTION</p> <p>4-20 mA signal: Switch 4 set to B Switch 5 set to B Switch 9 set to A Switch 10 set to A</p> <p>0-10 V signal: Switch 4 set to B Switch 5 set to B Switch 9 set to B Switch 10 set to B</p>
<p>The Actuator operates in positioner mode in local mode, not in remote mode</p>	<p>The Auto - 0% - 100% switch is not set to Auto. Signal defective</p> <p>Signal polarity</p>	<p>Check setting of Auto - 0% - 100% switch on the positioner board.</p> <p>Check the reference signal using a milliammeter connected in series (terminal 70). Check that the plus (+) of the signal is present at terminal 70.</p>
<p>The Actuator does not follow the input signal</p>	<p>Potentiometer reverse-mounted</p> <p>Signal reversed or configuration incorrect</p> <p>Rotational direction reversed</p>	<p>Check the potentiometer connection. The potentiometer should be connected to "POT STD" for :</p> <ul style="list-style-type: none"> • 4 mA (or (0 mA or 0 V according to signal) = closed position and clockwise direction closing. • 4 mA (or (0 mA or 0 V according to signal) = open position and counterclockwise direction closing <p>The potentiometer should be connected to "POT REV" for :</p> <ul style="list-style-type: none"> • 4 mA (or (0 mA or 0 V according to signal) = closed position and counterclockwise direction closing. • 4 mA (or (0 mA or 0 V according to signal) = open position and clockwise direction closing. <p>Check signal configuration. Switch #3 on positioner board: Position A: 4 mA = valve closed Position B: 4 mA = valve open</p> <p>Check signal configuration. Switch #3 on "Integral+" board: Position A: clockwise direction closing Position B: counterclockwise direction opening</p>

“ INTEGRAL + ” Controls

PROBLEM	CAUSE	CORRECTIVE ACTION
<p>The actuator does not stop on the closing limit switch.</p>	<p>The Actuator repeater potentiometer is incorrectly set.</p> <p>The motor has been unwired and rotates in the reverse direction (motor replacement).</p> <p>The Actuator is configured for torque closing.</p> <p>The closing limit switch is misadjusted.</p> <p>Position 0% is misadjusted.</p> <p>The motor has been unwired and rotates in the reverse direction (motor replacement).</p>	<p>Turn the Actuator potentiometer by a quarter-turn and repeat adjustments in accordance with commissioning instructions.</p> <p>When replacing a motor, wire markings must be observed. In case of doubt, check rotational direction. To reverse the motor rotational direction, change over wires 2 and 3 of the motor terminal strip.</p> <p>Check closing configuration (switch 1 of the "Integral+" board).</p> <p>Adjust the closing limit switch. The closing limit switch must be actuated with the valve closed (even if the Actuator is set for torque closing).</p> <p>Adjust Actuator potentiometer</p> <p>When replacing a motor, wire markings must be observed. In case of doubt, check rotational direction. To reverse the motor rotational direction, change over wires 2 and 3 of the motor terminal strip.</p>
<p>The Actuator does not stop on the opening limit switch</p>	<p>The opening limit switch is misadjusted.</p> <p>Position 100% is misadjusted</p> <p>The motor has been unwired and rotates in the reverse direction (motor replacement)</p>	<p>Adjust the opening limit switch. The opening limit switch must be actuated with the valve open.</p> <p>Adjust 100% potentiometer on positioner board.</p> <p>When replacing a motor, wire markings must be observed. In case of doubt, check rotational direction. To reverse the motor rotational direction, change over wires 2 and 3 of the motor terminal strip.</p>
<p>Indications are inoperative</p>	<p>The Actuator is "off"</p>	<p>Indications are only available with the Actuator "on".</p>
<p>The torque limiter indications are inoperative</p>	<p>Configuration incorrect</p> <p>The load limiter has been actuated</p>	<p>Check that the concerned indication relay has been configured for torque limiter indication. The jumper of the "Integral+" board is set to :</p> <p>TS0 for opening torque limiter</p> <p>TSC for closing torque limiter</p> <p>The electronics only store the limiter data if a manoeuvre is in progress. The electronics further only stores the data for</p>

“ INTEGRAL + ” Controls

PROBLEM	CAUSE	CORRECTIVE ACTION
The torque limiter indication does not return to initial reading once the torque limiter is no longer actuated.	manually. Torque limiter data storage	the load limiter corresponding to the rotational direction. The torque limiter data are stored electronically. To clear a torque limiter memory, a reverse order must be sent.
A fault is indicated but the Actuator is fully functional.	The datum signal is not present. In standard configuration, the Actuator indicates a fault and remains in position The selector switch is set to "local" or "off" position. In standard configuration the Actuator indicates a fault.	Send a control signal on the input Set the selector switch to "remote".